



FÉDÉRATION INTERNATIONALE
DE MOTOCYCLISME

TECHNICAL RULES
TRIAL

2017

*RÈGLEMENTS TECHNIQUES
TRIAL*

**Technical Rules Trial
(Including rules for Sidecars)**

2017

**Règlements Techniques Trial
(*Règlements pour Sidecars inclus*)**

Version 0
Applicable as from 01.01.2017

YEAR 2017		
Version	Applicable as from	Modified articles
0	01.01.2017	01.05, 01.07, 01.19, 19.01, 19.02, 19.04, 01.25, 25.01, 25.05, 01.27, 01.28, 31.01, 31.02, 35.05, 37.02, 41.03, 41.04, 49.08.2, 50.02.3, 50.04, 53.01, 53.13, 63.01.2, 63.05, 65.01, 65.02, 65.04, 01.67, 69.02, 01.70, 01.73, 77.01, 77.03, 77.04, 77.05, 01.79, 79.02, 79.03, 79.04
1		
2		
3		
4		

Table of contents

01.01	INTRODUCTION.....	4
01.03	FREEDOM OF CONSTRUCTION	4
01.05	CATEGORIES AND GROUPS OF MOTORCYCLES	4
01.07	CLASSES.....	5
01.11	MEASUREMENT OF CAPACITY	5
01.17	SUPERCHARGING	6
01.18	TELEMETRY.....	7
01.19	MOTORCYCLE WEIGHTS	7
01.21	DESIGNATION OF MAKE	8
01.23	DEFINITION OF A PROTOTYPE	8
01.25	GENERAL SPECIFICATIONS	8
01.26	DEFINITION OF A FRAME OF A SOLO MOTORCYCLE	9
01.27	STARTING DEVICES	9
01.28	FUEL TANKS	9
01.29	OPEN TRANSMISSION GUARDS	10
01.31	EXHAUST PIPES AND SILENCERS	10
01.33	HANDLEBARS.....	11
01.35	CONTROL LEVERS	12
01.37	THROTTLE CONTROLS	12
01.39	FOOTRESTS	13
01.41	BRAKES	13
01.43	MUDGUARDS AND WHEEL PROTECTION	14
01.47	WHEELS, RIMS, AND TYRES.....	14
01.49	TRIAL TYRES	14
01.50	ADDITIONAL SPECIFICATIONS FOR ELECTRIC POWERED VEHICLES (EPVs, Group J)	15
01.53	ADDITIONAL SPECIFICATIONS FOR SIDECARS	20
01.56	LEGAL CONFORMITY OF THE MOTORCYCLES AND THEIR.....	22
01.63	FUEL, OIL AND COOLANTS.....	22
01.65	EQUIPMENT AND PROTECTIVE CLOTHING DURING PRACTICE AND RACE	30
01.67	WEARING OF HELMETS	30
01.69	HELMET OPERATIVE INSTRUCTIONS	31
01.70	RECOGNISED INTERNATIONAL HELMET APPROVAL MARKS	32
01.73	NATIONAL COLOURS FOR HELMETS	33
01.75	BADGE OF THE FIM	34
01.77	TECHNICAL VERIFICATIONS	35
01.78	DANGEROUS MACHINES	38
01.79	SOUND LEVEL CONTROL.....	38

Rule changes as of 01.01.2018

DIAGRAMS

01.01 INTRODUCTION

The term motorcycle covers all vehicles having, in principle, less than four wheels, propelled by an engine and designed essentially for the carriage of one or more persons of which one is the rider of the vehicle. The wheels must normally be in contact with the ground except momentarily or in certain exceptional circumstances. Furthermore, in order to traverse certain surfaces one or all of the wheels can be replaced with skis, rollers or chains.

01.03 FREEDOM OF CONSTRUCTION

A motorcycle must conform to the requirements of the FIM regulations, to the Supplementary Regulations, as well as to a number of specific conditions that the FIM may require for certain competitions. No restriction is placed on the make, construction or type of motorcycle used.

All solo motorcycles (Group A1) must be constructed in such a way that they are entirely controlled by a rider. Motorcycles with Sidecars (Group B) must be constructed to carry a passenger.

01.05 CATEGORIES AND GROUPS OF MOTORCYCLES

Motorcycles are divided into categories and groups which must be observed for all meetings.

In principle, it is forbidden for different categories, groups and classes to compete together, unless the Supplementary Regulations state otherwise.

Category I

Vehicles propelled by the action of only one driving wheel in contact with the ground in only one direction.

Group A1 - Solo Motorcycles

Two-wheel vehicles making only one track on the ground.

Group B1

Vehicles with three wheels making two tracks on the ground, consisting of a motorcycle making one track and a Sidecar for a passenger making the other.

Group B2 - Motorcycles with permanent Sidecar

Vehicles with three wheels making two or three tracks on the ground in the direction of forward travel, with a permanently attached Sidecar forming a complete integral unit.

If three tracks are made, the centre-lines of the two tracks made by the motorcycle wheels must not be more than 75 mm apart. A track is determined by the longitudinal centre-line of each of the vehicle's wheels in the direction of forward travel.

Category II

Vehicles propelled by the action of two driving wheels in contact with the ground in only one direction.

Group C - Special 2 wheel driven motorcycles

Group D - Special 3 wheel, 2 wheel driven motorcycles

Category III

Group J – Electric Powered Vehicles (EPVs, see Art. 01.50)

01.07 CLASSES

Groups are again separated into classes according to cylinder capacities as detailed below. Generally, these classes must be observed for all meetings. **For the detailed example of World Championship/Cup events, refer to the Trial Sporting Rules.**

Category I

Group A1 - Solo Motorcycles

Class	over (cc)	up to (cc)
50	-	50
TRIAL125	50	125
TRIAL2	125	250 (2-stroke) 300 (4-stroke)
TRIALGP	250	-

Groups B1, B2 - Sidecars

Same as groups A1 over 125 cc.

Category II

Same as groups A1 over 125 cc.

Category III

Same as groups A1 over 125 cc.

01.11 MEASUREMENT OF CAPACITY

11.11 Reciprocating movement engine, "Otto" Cycle

The capacity of each engine cylinder is calculated by the geometric formula which gives the volume of a cylinder; the diameter is represented by the bore, and the height by the space swept by the piston from its highest to lowest point:

$$\text{Capacity} = \frac{D^2 \times 3.1416 \times C}{4}$$

where D = bore
and C = stroke

When a cylinder bore is not circular, the cross sectional area must be determined by a suitable geometrical method or calculation, then multiplied by the stroke to determine capacity.

When measuring, a tolerance of 1/10 mm is permitted in the bore. If with this tolerance the capacity limit is exceeded for the class in question, a further measurement should be taken with the engine cold, to 1/100 mm limits.

11.13 Rotary engines

The capacity of an engine which determines the class in which the motorcycle shall compete in a meeting shall be calculated by:

$$\text{Capacity} = \frac{2 \times V}{N}$$

where V = total capacity of all the chambers comprising the engine
and N = number of turns of the motor necessary to complete one cycle in a chamber.

This engine is classified as a 4-stroke.

11.15 Wankel system

For Wankel system engines with a triangular piston, the capacity is given by the formula:

$$\text{Capacity} = 2 \times V \times D$$

where V = capacity of a single chamber
and D = number of rotors

This engine is classified as a 4-stroke.

01.17 SUPERCHARGING

Supercharging by means of a device of any kind is forbidden in all meetings.

An engine, whether 2-stroke or 4-stroke, coming within any one of the recognised classes (determined by the capacity of the working cylinder) shall not be considered as supercharged when, in respect of one engine cycle, the total capacity, measured geometrically, of the fuel charging device or devices, including the capacity of the working cylinder (if used for injecting the fuel), does not exceed the maximum capacity of the class in question.

01.18 TELEMETRY

Information must not be transmitted in any way to or from a moving motorcycle.

An official signalling device may be required on the machine.

Automatic lap timing devices are not considered as “telemetry”.

Automatic lap timing devices shall not disrupt any official time keeping methods and equipment.

01.19 MOTORCYCLE WEIGHTS

The present rule is established with a minimum validity of 3 years starting from 01.01.2017.

19.01

The minimum weights (**without rider and/or passenger**) of the Trial motorcycles are:

- For Class 125: **67 kg**
- For Class OPEN: **69 kg**

except where otherwise specified (see Art. 01.50 for Group J: Powered Electric Vehicles).

These are absolute limits and no tolerance is applied when the machine is checked before the race.

The minimum weight of the verified motorcycle must not **at any time be** less than the minimum weight required.

A 1% tolerance in the weight of the machine is accepted when checked during or after the event, in order to take into account the variability of the test conditions.

A scale with a minimum resolution of 100g must be used.

A rider may be asked to submit his/her machine for a weight control in between laps or after the last lap.

These weight checks will be performed in the shortest amount of time possible.

19.02

The use of ballast to stay over the minimum weight is forbidden. The term "ballast" refers to as any component, device or part, the primary function of which is to add weight to the machine. All ways to add weight to the machine must be firmly fixed to the motorcycle.

19.03

A sticker or other piece of material (preference goes to plastics) must be fixed to the front of the main frame (and with preference on the same side of the frame on all the motorcycles).

19.04

Weighing scales must have been certified by a National Institute **within the period of 24 months before the event.**

19.05

For Groups B1 and B2 at all competitions a passenger must be carried.

01.21 DESIGNATION OF MAKE

When two manufacturers are involved in the construction of a motorcycle the name of both must appear on the machine as follows:

- The name of the chassis manufacturer
- The name of the engine manufacturer

01.23 DEFINITION OF A PROTOTYPE

A prototype motorcycle is a vehicle which must conform to the safety requirements as required by the FIM Sporting Code and Appendices applicable to the type of competition for which it is to be used.

01.25 GENERAL SPECIFICATIONS

The following specifications apply to all vehicles of the groups indicated and to all types of competitions except where otherwise stated in the corresponding section of the FIM Sporting Code.

Further specifications for some competitions may also be required and these will be detailed in either the appropriate FIM Appendix or in the Supplementary Regulations for the competition in question.

Concerning material verification, in case of doubt, a sample/part in question shall be taken and analysed at a Material Testing laboratory.

25.01 Use of titanium

The use of titanium in the construction of the frame, the front forks, the handlebars, the swinging arms, **the wheel- and swinging arm-spindles** is forbidden.

The use of titanium alloy nuts and bolts is allowed.

25.03 Carbon fibre

The use of carbon fibre reinforced materials is authorised (with the exception of handlebars and wheel rims).

25.04 Ceramic materials

The use of ceramic parts is forbidden.

25.05 Other equipment

The use of data recording devices and automatic electronic ignition is authorised.

No signal of any kind may pass between a moving motorcycle **and any person, including radio and Bluetooth communication**. The exception is for the signal from the time keeping transponder, automatic lap timing devices or from the approved on-board cameras (with prior written approval from the Championship Promoter/Organiser, **which cannot be granted for helmet mounted cameras**).

25.06 Number of cylinders

The number of cylinders in an engine is determined by the number of combustion chambers.

25.07

If separate combustion spaces are used they must be connected by an unrestricted passage of minimum cross sectional area at least 50% of the total inlet port area.

01.26 DEFINITION OF A FRAME OF A SOLO MOTORCYCLE

The structure or structures used to join any steering mechanism at the front of the machine to the engine/gear box unit and to all components of the rear suspension.

01.27 STARTING DEVICES

Starting devices **for the engine** are compulsory.

01.28 FUEL TANKS

The fuel tank and oil tank must be securely mounted.

The fuel tank must be marked throughout the event. Unmarked fuel tanks will be reported to the Jury President.

Fuel tanks shall only be filled in **officially designated "refuelling area(s)", which shall be equipped with fire extinguishers and environmental mats. The Promoter/Organiser shall inform the participants on the location of these areas.**

01.29 OPEN TRANSMISSION GUARDS

A guard must be fitted to the countershaft sprocket.

29.04

A chain guard must be fitted in such a way to prevent trapping between the lower chain run and the final driven sprocket at the rear wheel.

The external side of the rear sprocket must be completely covered by a hard, solid plastic sheet. No holes on the sprocket may remain visible.

01.31 EXHAUST PIPES AND SILENCERS

Exhaust pipes and silencers must fulfil all the requirements concerning sound control (see also Art. 01.79).

31.01

The axis of the silencer end must be parallel (tolerance 10°) to the central axis of the vehicle. The extremity of the silencer must not pass the vertical tangent of the rear tyre.

31.02

The edge of the silencer shall not be dangerous in case of accidental contact with the riders or helpers. If the edge of the final tube protrudes more than 3 mm, it must be rolled to an angle of 180° (see picture below).

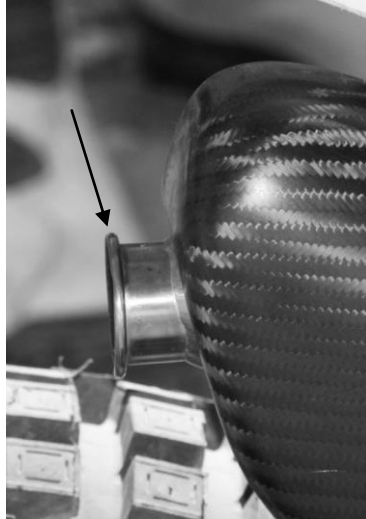

31.03

Exhaust fumes must be discharged towards the rear but not in such a manner as to raise dust, foul the tyres or brakes, or inconvenience the passenger (in the case of sidecars), or any other rider.

01.33 HANDLEBARS

33.01

The width of handlebars must be not less than 600 mm and not more than 850 mm.

33.02

The handlebars must be equipped with a protection pad on the cross bar. Handlebars without a cross member must be equipped with a protection pad located in the middle of the handlebars, covering widely the handlebars clamps.

33.03

Handlebar clamps must be very carefully radiused and engineered so as to avoid any fracture points in the handlebar.

When light alloy handlebars are used, the distance between the two extremities of the clamping area (or of the 2 clamps) must not be less than 120 mm.

33.04

Exposed handlebar ends must be plugged with a solid material or rubber covered.

33.06

When hand protectors are used, these must be made of a shatter-resistant material and have a permanent opening for the hand.

33.07

Handlebars made of composite materials are not authorised.

33.08

Repair by welding of light alloy handlebars is prohibited.

33.09

Solid stops (when on full-lock, other than steering dampers) must be fitted. These must ensure a minimum clearance of 30 mm between the handlebar with levers and the tank to prevent trapping the rider's fingers.

33.10

For Sidecars in trial, the minimum angle of rotation of the handlebar on each side of the centre line or mid-position must be at least 40°. The steering must be effected only through the motorcycle front wheel and its steering fork. A steerable sidecar wheel is forbidden.

01.35 CONTROL LEVERS

35.01

All handlebar levers (clutch, brake, etc.) must be in principle ball ended (diameter of this ball to be at least 16 mm). This ball can also be flattened, but in any case the edges must be rounded (minimum thickness of this flattened part 14 mm). These ends must be permanently fixed and form an integral part of the lever.

35.03

Each control lever (hand and foot levers) must be mounted on an independent pivot.

35.04

The brake lever if pivoted on the footrest axis must work under all circumstances, such as the footrest being bent or deformed.

35.05

Hand- and foot-controls may be modified for mobility challenged riders.

01.37 THROTTLE CONTROLS

37.01

Throttle controls must be self-closing when not held by the hand. The throttle operation (opening and closing) shall only be activated by mechanical cable from the

twist grip directly attached to the throttle valve. All air intakes into the cylinder must pass through the throttle body. No other means allowing ambient air into the inlet track of the cylinder head are allowed.

37.02 Ignition cut-out switches

It is compulsory that all motorcycles be equipped with an operational cut-off switch, connected through a lanyard to the rider (max. length - 1m). Once the rider steps off the motorcycle, the lanyard must disconnect from the cut-off switch and **cut the power to the engine.**

In the case of vehicles belonging to Group J (Electric vehicles), refer to Art. 50.04.6.

01.39 FOOTRESTS

39.01

Footrests must be solidly fixed. They may be of a folding type but in this case must be fitted with a device which automatically returns them to the normal position, and an integral protection is to be provided at the end of the footrest which must have at least 8 mm radius (see Diagram D).

01.41 BRAKES

41.01

All motorcycles must have at least two efficient brakes (one on each wheel) operated independently and operating concentrically with the wheel.

41.02

Vehicles in Group B must be fitted with at least two efficient brakes operating on at least two of the wheels and operated independently and operating concentrically with the wheels.

41.03

Brake discs with sharp edges (saw tooth design) are forbidden. **The maximum dimensions allowed for openings will be: diameter of the holes: 6 mm; width of the slots: 6 mm. See Diagrams section.**

41.04

An external protection made from a **rigid** plastic material must cover the front and rear brake discs (fully in the front, partially on the rear). Holes for aeration and evacuation of materials shall not be more than 10 mm in diameter or equivalent area.

01.43 MUDGUARDS AND WHEEL PROTECTION

Motorcycles must be fitted with mudguards.

43.01

The front mudguard must cover at least 100° of the circumference of the wheel. The angle formed by one line drawn from the front edge of the mudguard to the centre of the wheel and one drawn horizontally through the centre of the wheel must be between 45° and 60°.

43.02

The rear mudguard must cover at least 80° of the circumference of the wheel. The angle formed by two lines, one drawn from the rear edge of the mudguard to the centre of the wheel and one drawn horizontally through the centre of the wheel, shall not exceed 60°.

01.47 WHEELS, RIMS, AND TYRES

47.01

All tyres will be measured mounted on the rim at a pressure of 1 kg/sq.cm (14 lb./sq.in); measurements are taken at a tyre section plane with a 90° angle with the ground plane.

47.02

Any modification to the rim or spokes of an integral wheel (cast, moulded, riveted) as supplied by the manufacturer, or of a traditional detachable rim other than for spokes, valve or security bolts, is prohibited.

The only exception is for tyre retention screws sometimes used to prevent tyre movement relative to the rim.

If the rim is modified for these purposes, bolts, screws etc., must be fitted.

01.49 TRIAL TYRES

49.01

The overall width of the tyre when fitted must not exceed 115 mm.

49.02

The tread groove depth (A) must not exceed 13 mm. Such a depth shall be measured between the "minimum" of the tread groove and a line tangent with the top of the block. All blocks in the same circumference must be of the same depth (see Diagram D bis).

49.03

The space between the blocks must not exceed 9.5 mm across the tyre (B) or 13 mm in a circumferential direction (C).

49.04

The space between shoulder blocks (D) must not exceed 22 mm.

49.05

The space across the tread (E) cannot extend completely across the tyre, measured at right angles to the wall of the tyre, unless broken by a block.

49.06

All tread blocks (with the exception of the shoulder blocks) must be nominally rectangular with sides parallel with or at right angles to the tyre axis (tyre must have same appearance when reversed and conform, in principle, to Diagram D bis).

49.08

Only tyres normally available from commercial or retail sources for use on the public highway are authorised.

49.08.1 The tyres shall appear in the tyre manufacturers range catalogue or tyre specification lists available to the general public.

49.08.2 They shall be approved according to UN Vehicle Regulation 75 Rev. 2 (2010) with the following specific features:

- Category of use (5.2): it shall be "snow" or "special" or "All terrain"
- Speed category symbol (5.4): M (130 Km/h) or above
- Load capacity index (5.5): 45 (165 Kg) or above.

It is recommended that the tyres be used according to the European Tyre and Rim Technical Organisation (ETRTO) guidelines.

01.50 ADDITIONAL SPECIFICATIONS FOR ELECTRIC POWERED VEHICLES (EPVs, Group J)

50.01 Introduction

EPVs refer to two- and/or three-wheeled autonomous electric powered motorcycles, having traction on one or both wheels (with an unpowered sidecar if applicable).

The number of electric motors is free.

Amendments to these technical regulations may be made at any time in order to ensure fair competitions.

50.02 Specific class requirements

50.02.1 Race Procedures

Same as category I, Group A1, class 125 motorcycles.

50.02.2 Race Format

Same as category I, Group A1, class 125 motorcycles.

50.02.3 Charging the accumulator

Energy supply will be provided in the paddock at the times and locations determined by the Organiser.

Charging may only be done with the energy supply provided by the race Organiser.

The charging system must be separate from the machine and comply with all electrical safety requirements including thermal overload trip, fusing and be equipped with a ground leakage circuit breaker protection.

50.02.4 Pit Stop

Riders will be allowed to define their own method of energy renewal subject to safety and practical considerations subject to the approval of the race organiser.

Riders who wish to have a pit stop must declare the process and technology to the Technical Director/Chief Technical Steward for a safety evaluation. All information will be treated with strict confidentiality.

50.02.5 Transponder timing

Machines may be equipped with an official transponder.

50.02.6 Technical Verifications

As a condition of entry, all safety items on-board the motorcycle must be precisely described and presented at the Technical Verifications.

The Technical Director shall check both the motorcycle and the rider for compliance with the technical specifications, as well as the employment of good engineering construction practice, the provision of adequate electrical insulation and weatherproofing.

The rider shall present his helmet, gear, bib, gloves and boots to the Technical Verifications to demonstrate good condition and fit. Refer to Art. 01.65.

Damaged motorcycles must be returned to the Technical Verifications area for examination after race or practice. In such circumstances it is the responsibility of the competitor to ensure both his machine and clothing have been rechecked and approved before further use in the event. If stickers/marks are used, a new sticker/mark must be in place.

It is the responsibility of the rider to ensure that a machine used in competition is electric, mechanically and structurally in a safe condition.

In case of a dispute, the decision of the Technical Director will be final.

50.02.7 Conformity

It is the duty of each competitor to show the Technical Stewards of the meeting that his/her vehicle fully complies with these rules and the rules governing the meeting in their entirety at all times.

50.03 General vehicle specifications

50.03.1 Requirements

All motorcycles must comply in every respect with all the requirements for racing as specified in these rules, unless otherwise specified.

The power circuit consists of all those parts of the electrical equipment which are used to propel the motorcycle. The on-board circuit consists of all those parts of the electrical equipment which are used for signalling, lighting or communication.

The accumulator is defined as any on-board equipment used for the storage of electrical energy supplied by the charging unit.

Recovering energy generated by the kinetic energy of the vehicle is permitted.

The use of any external source of energy in any form whatsoever with the aim of improving the performance of the vehicle is strictly prohibited.

50.03.3 Handlebars

See Art. 01.33.

50.03.4 Control levers

See Art. 01.35.

50.03.5 Foot Rests

See Art. 01.39.

50.03.6 Wheel and rims

See Art. 01.47.

50.03.7 Tyres

See Art. 01.49.

50.03.9 Machine Weight

No minimum weight is required.

50.03.10 Overall Dimensions

Same as category I, group A1, class 125 motorcycles.

50.04 Electrical safety

It must be ensured that the components used cannot cause injury under any circumstances, either during normal operation or in foreseeable cases of malfunction. It must be ensured that the components used for protecting persons or objects can reliably fulfil their function for an appropriate length of time.

50.04.1 Electrical components

All parts of the electrical equipment must be protected to at least the equivalent of IP 44 type protection (dust proof and splash proof). Exposed connectors/wires must be protected against abrasion in case of accident (side covers).

It must be ensured that the electrical components used cannot cause injury under any circumstances, either during normal operation or in foreseeable cases of malfunction. It must be ensured that the components used for protecting persons or objects can reliably fulfil their function during the period of the competition.

50.04.2 Power bus maximum voltage

The maximum allowed voltage in the main power bus is 120VDC or 85VAC. A secondary power bus may be used to supply energy to the critical systems at a maximum voltage of 20VDC or 14VAC.

50.04.3 High voltage symbols

Symbols warning of 'HIGH VOLTAGE' must be displayed on or near the electrical equipment protective covers; all symbols must comprise a black flash of lightning inside a yellow triangle with a black border. The sides of the triangle must measure at least 8 cm, but may be larger if practical.



50.04.4 Insulation

Every part of the electrical equipment must be electrically insulated relative to all live components and system ground. Maximum default current is 1mA.

Wiring insulators can be required to be checked at any time by the FIM Technical Director. Double insulation will be required in high voltage or high current wires. The technical data sheets of the wires used will prevail under all circumstances.

Plus and minus wires from the battery must be insulated with respect to the chassis to withstand battery maximum voltage at least.

All electrically conducting non-live parts must be connected with the system ground.

In cases where the voltage of the power circuit exceeds 36VDC, the power circuit must be separated from the on-board circuit by an appropriate insulator.

Insulating material not having sufficient mechanical resistance, i.e. paint coating, enamel, oxides, fibre coatings (soaked or not) or insulating tapes are not accepted.

50.04.5 Power Indicator

When the vehicle is in a powered on state, there must be two clearly visible indicators, one light on the instrument panel and one light on the rear of the vehicle.

The rear light must be red and visible from at least 10m away, from the rear or the side.

50.04.6 General circuit breaker – 'Emergency Stop'

The lanyard must disconnect from the cut-off switch and discharge the main bus voltage below 60V. This system will be referred to as general circuit breaker or "Emergency stop".

Low power accumulators provided for low voltage circuits, e.g. auxiliary circuits, do not have to be isolated by the general circuit breaker (Emergency Stop) provided that they are completely isolated from the main power accumulators.

50.04.7 Fuses (over-current trip switches)

An over-current trip is a device which automatically interrupts the electrical current in which it is installed if the level of this current exceeds a defined limit value for a specific period of time.

Over-current trips must under no circumstances replace the general circuit breaker (Emergency Stop).

50.04.8 Capacitors

Voltage across capacitors belonging to the power circuit should fall below 65 volts within 5 seconds after the general circuit breaker is opened or the over-current trips of the accumulator are blown.

50.04.9 Power control

A 'self-closing' throttle (power control) must be applied.

50.04.10 Accumulator (storage battery)

The type, dimensions and weight of accumulator/s cannot be changed between official practices and race, including the exchange of accumulators.

IMPORTANT: As a condition of entry, a Material Safety Data Sheet (MSDS) for the accumulator, including all relevant details as to the energy accumulator chemistry, light metals content, human and environmental hazards, handling and specific fire risks and precautions, must be always available for the Technical Verifications.

50.04.11 Accumulator fastening

The accumulator must be installed securely inside the vehicle and be protected against short-circuits and leakage. The accumulator must be attached to the frame or chassis using metal clamps with an insulating covering.

The fixing method must be designed in such a way that neither the accumulator nor the fastening device itself nor its anchorage points can come loose, even when subjected to a crash.

A solid partitioning bulkhead must separate the location of the accumulator from the rider. Each accumulator box must provide its own cooling and/or venting system. In modular battery systems, a heat shield is strongly recommended between modules, by means of an adiabatic shield or intumescent protection.

The accumulator installation must ensure that in the event of accumulator cell leakage or explosion, the contents are kept away from the rider and do not interfere in any way with the rider's vision or the safe handling of the machine.

01.53 ADDITIONAL SPECIFICATIONS FOR SIDECARS

53.01

The Sidecar must be fixed to the motorcycle in at least three points, if it is not an integral part of the chassis.

The fixing points must not allow movement at the joints (articulated Sidecars are strictly forbidden). If the angle of the inclination is changeable, it must be locked in such a way that the fixing method is completely secured and not only clamped on.

A structure of crossed belts or a metallic grid must be fitted to fill the opening between the wheels and the sidecar, to prevent the rider's foot from accidentally touching the ground.

The fuel tank must be sufficiently and independently protected from the ground.

53.06

The drive shall be transmitted to the ground only through the rear wheel of the motorcycle.

53.07

The distance between the tracks left by the centre lines of the rear motorcycle wheel and the Sidecar wheel must be at least: 800 mm and not more than 1150 mm.

53.09

To reduce the torque in the steering, a maximum displacement of 75 mm is permitted between the front and the rear wheel.

53.10

The steering of the front wheel must be accomplished without any intermediate articulated steering joints directly by a classic telescopic fork or a swinging arm fork with the wheel supported equally each side (long or short leading link type). All other types of front wheel steering and suspension are forbidden.

53.11

The minimum dimensions of a Sidecar available for passenger accommodation are:

Length: 1 350 mm - Width: 300 mm (See Diagram N).

53.12

The minimum ground clearance of a laden Sidecar when measured must not be less than 175 mm.

53.13

The position of the engine is optional, except that it must be positioned in front of the rear wheel.

The centre line of the engine corresponds to the crankshaft axis (for longitudinal engines) and to the centre line of the cylinders block (for transverse engines). The centre line of the engine shall not exceed more than 160 mm beyond the centre line of the rear wheel of the motorcycle.

If the engine and gearbox are mounted on plates, the minimum thickness of the steel plates must be 4 mm, and 5 mm for light alloy plates.

53.14

Handlebars must be firmly secured to the forks. They must be at a height above the mid-point in the seat.

The motorcycle must have a steering head which must be fitted like the handlebar, and must not be attached to the unsuspended part of the front wheel suspension.

53.15

The seat must have minimum dimensions of 300 mm x 150 mm and must be fixed at a minimum height of 300 mm above the Sidecar floor (see Diagram N).

53.16

For Sidecars, the rear wheel and the Sidecar wheel must be covered or protected with a solid material.

53.17

Referring to the longitudinal axis of the motorcycle, the exhaust pipe shall not protrude beyond the width of the sidecar (if on the sidecar side) or protrude by more than 330 mm (if on the motorcycle side) (see Diagram N).

If the exhaust pipe is on the sidecar side, it must not exceed the vertical line drawn at a tangent to the rear edge of the Sidecar platform.

01.56 LEGAL CONFORMITY OF THE MOTORCYCLES AND THEIR REGISTRATION PLATES

Motorcycles and their equipment must comply with the national legal requirements for road traffic of the country in which the vehicle is registered and with other rules specified in the Supplementary Regulations.

The electrical generator must operate continuously and normally with respect to current and voltage during the competition and at post competition control. The electrical connections must be retained.

01.63 FUEL, OIL AND COOLANTS

All motorcycles must be fuelled with unleaded petrol, as this term is generally understood.

All riders/teams must declare to the FIM Technical Steward the make and type of fuel used during practices and race(s), upon presentation of the riders' motorcycle(s) at the initial Technical Verifications. See also: Art. 63.04.2.

63.01 Physical properties for unleaded fuel

63.01.1 Unleaded petrol must comply with the FIM specification.

63.01.2 Unleaded petrol (incl. E10) will comply with the FIM specification if:

NOTE: The present rule will be subject to change as of 01.01.2018 (see end of the document).

a) It has the following characteristics:

Property	Units	Min.	Max.	Test Method
RON		95.0	102.0	EN ISO 5164
MON		85.0	90.0	EN ISO 5163
Oxygen	% (m/m)		2.7	ISO 22854 or EN 13132
Oxygen (E10 Fuels)	% (m/m)		3.7	ISO 22854 or EN 13132
Nitrogen	% (m/m)		0.2	ASTM D 4629
Benzene	% (V/V)		1.0	ISO 22854 or EN 238
Vapour pressure (DVPE)	kPa		95.0	EN 13016-1
Lead	mg/L		5.0	ICP-OES or AAS
Manganese	mg/L		2.0	ICP-OES or AAS
Density at 15°C	kg/m ³	720.0	775.0	EN ISO 12185
Oxidation stability	minutes	360		EN ISO 7536
Existent gum	mg/100 mL		5.0	EN ISO 6246
Sulphur	mg/kg		10.0	EN ISO 20846 or 20884
Copper corrosion	rating		class 1	EN ISO 2160
Distillation:				EN ISO 3405
E at 70°C	% (V/V)	20.0	50.0	
E at 100°C	% (V/V)	46.0	71.0	
E at 150°C	% (V/V)	75.0		
Final Boiling Point	°C		210	
Residue	% (V/V)		2.0	
Appearance	Clear and bright			Visual inspection
Olefins	% (V/V)		18.0	EN ISO 22854
Aromatics	% (V/V)		35.0	EN ISO 22854
Total diolefins	% (m/m)		1.0	GC-MS or HPLC
Oxygenates:				EN ISO 22854* or EN 13132
Methanol	% (V/V)		3.0	
Ethanol (1)	% (V/V)		5.0	
Ethanol (E10) (1)	% (V/V)	5.0	10.0	
Isopropanol	% (V/V)		12.0	
Isobutanol	% (V/V)		15.0	
<i>tert</i> -Butanol	% (V/V)		15.0	

Ethers (C5 or higher)	% (V/V)		22.0	
Others (2)	% (V/V)		15.0	
Property	Units	Min.	Max.	Test Method
RON		95.0	110	EN ISO 5164
MON		85.0	100	EN ISO 5163
Vapour pressure (DVPE)	kPa	35.0	95.0	EN 13016-1
Lead	g/L		0.001	ICP-OES
Manganese	g/L		0.001	ICP-OES
Oxidation stability	Minutes	360		EN ISO 7536
Existent gum	mg/100 mL		5.0	EN ISO 6246
Sulphur	mg/kg		10.0	EN ISO 20846 or 20884
Copper corrosion	Rating		Class 1	EN ISO 2160
Distillation:				
Final Boiling Point	°C		210	EN ISO 3405
Residue	% (V/V)		2	EN ISO 3405
Appearance	Clear and bright			Visual inspection
Ethanol + higher alcohols	% (V/V)	75		EN 13132 or 14517
Higher alcohols (C3-C8)	% (V/V)		2.0	EN 13132 or 14517
Methanol	% (V/V)		1.0	EN 13132 or 14517
Ethers (5 or more C atoms)	% (V/V)		5.2	EN 13132 or 14517
Unleaded petrol as specified in 2.10.1.2	% (V/V)	14	25	
Water	% (V/V)		0.3	EN 12937
Inorganic chloride	mg/L		1	EN 15484
Acidity (as acetic acid)	% (m/m) (mg/L)		0.005 (40)	EN 15491

Notes:

* Preferred method.

(1) Ethanol must be blended according to EN 15376.

(2) GC-MS methods may also be applied to fully deconvolute GC trace.

b) The total of individual hydrocarbon components present at concentrations of less than 5% m/m must constitute at least 30% m/m of the fuel. The test method will be gas chromatography and/or GC/MS.

c) The total concentration of naphthenes, olefins and aromatics classified by carbon number must not exceed the values given in the following table:

% (m/m)	C4	C5	C6	C7	C8	C9+
Naphthenes	0	5	10	10	10	10
Olefins	5	20	20	15	10	10
Aromatics	-	-	1.2	35	35	30

The total concentration of bicyclic naphthenes and bicyclic olefins may not be higher than 1% (m/m). The test method used will be gas chromatography.

d) Only the following oxygenates are permitted:

Methanol, Ethanol, n-Propyl alcohol, Isopropyl alcohol, n-Butyl alcohol, sec-Butyl alcohol, Isobutyl alcohol, tert-Butyl alcohol; Methyl tertiary butyl ether, Ethyl tertiary butyl ether, Tertiary amyl methyl ether, Diisopropyl ether.

- e) Manganese is not permitted in concentrations above 2.0 m/L. For the present this is solely to cover possible minor contamination by other fuels.

Lead replacement petrols, although basically free of lead, are not an alternative to the use of unleaded petrol. Such petrols may contain unacceptable additives not consistent with the FIM Fuel Regulations.

63.01.3 Ethanol E85 will comply with the FIM specification if:

- a) It has the following characteristics:

Property	Units	Min.	Max.	Test Method
RON		95.0	110	EN ISO 5164
MON		85.0	100	EN ISO 5163
Vapour pressure (DVPE)	kPa	35.0	95.0	EN 13016-1
Lead	g/L		0.001	ICP-OES
Manganese	g/L		0.001	ICP-OES
Oxidation stability	Minutes	360		EN ISO 7536
Existent gum	mg/100 mL		5.0	EN ISO 6246
Sulphur	mg/kg		10.0	EN ISO 20846 or 20884
Copper corrosion	Rating		Class 1	EN ISO 2160
<u>Distillation:</u>				
Final Boiling Point	°C		210	EN ISO 3405
Residue	% (V/V)		2	EN ISO 3405
Appearance	Clear and bright			Visual inspection
Ethanol + higher alcohols	% (V/V)	75		EN 13132 or 14517
Higher alcohols (C3-C8)	% (V/V)		2.0	EN 13132 or 14517
Methanol	% (V/V)		1.0	EN 13132 or 14517
Ethers (5 or more C atoms)	% (V/V)		5.2	EN 13132 or 14517
Unleaded petrol as specified in 2.10.1.2	% (V/V)	14	25	
Water	% (V/V)		0.3	EN 12937
Inorganic chloride	mg/L		1	EN 15484
Acidity (as acetic acid)	% (m/m) (mg/L)		0.005 (40)	EN 15491

63.02 Oil

For oil used in two stroke mixtures, the following tolerances on the fuel specifications will be allowed:

Density at 15°C	Plus/minus 30 kg/m ³
-----------------	---------------------------------

Distillation residue	Not controlled
----------------------	----------------

Any infringement of the fuel specifications will automatically result in the exclusion of the competitor from the entire meeting (see also Sporting Code Art. 140.1). The result of the competitors' fuel sample analysis (A or B Sample) more favourable to the competitor will be taken into account (See also Art. 63.05.3).

If the fuel available locally for the event is not of a sufficient quality for use by competitors, the FMN of the organising country must ask the FIM for a waiver in order to enable the use of fuel not corresponding to the characteristics defined above.

All possible measures must be taken to prevent the possible loss of waste oil so that it does not inconvenience a following rider.

63.03 Air

Only ambient air may be mixed with the fuel as an oxidant.

63.04 Primary Tests

63.04.1 The FIM may require tests of fuels to be administered before, or at the time of delivery to, an event at which such fuels are to be used.

63.04.2 Fuel companies which supply 'race' fuels (fuels other than those obtained at public fuel stations) to participating teams/riders must submit 10 litres (2 x 5 L) to the laboratory appointed by the FIM/DWO for analysis in accordance with the specification.

Providing the fuel is within the specification, a certificate containing a test report and batch number will be issued to the fuel company.

The fuel company must provide a copy of the test report number to their client rider/teams before they take part in a race.

Contact for fuel analysis: fimfuels@intertek.com.

63.05 Fuel Sampling and Testing

- 1) The FIM-appointed Official has the sole responsibility for the management and supervision during the taking of fuel samples.
- 2) The preferred fuel test method is Gas chromatography or GC Fingerprint method.

Gas chromatography (GC) is an analytical technique for separating compounds based primarily on their volatility and polarity. Gas chromatography provides both qualitative and quantitative information for individual compounds present in a sample. Gas chromatography is widely used for the analysis of fuels.

The GC Fingerprint is a comparison between the given reference and the fuel drawn from the competitor's motorcycle. With the fingerprint method any

changes in the composition and concentration of the fuel against the reference is detected. The separation is done with a non-polar column suitable for fuel analysis. The detection of the components is done with a flame ionisation detector.

- 3) If other test methods are required, fuel samples are transported to the appointed laboratory by an official courier, using the appropriate containers.
- 4) Riders selected for fuel controls are directed with their motorcycles to the inspection area.
- 5) Only new sample bottles are used for the fuel samples.
- 6) The fuel to be tested is transferred directly from the selected fuel tank into three vials (3 small sample containers), marked A, B and C and identified by reference to the motorcycle from which the sample was taken. The bottles are closed, sealed and labelled by the FIM appointed Official.
- 7) The Fuel Sample Declaration form (see 14) is filled out immediately, containing all information as shown on the sample sheet, including the riders' name and race number, date and place of fuel sampling. A responsible team member signs this declaration, after verifying that all the information is correct.
- 8) Samples A and B are given to the appointed laboratory staff, present at the event for analysis or be sent to the respective laboratory by the organiser if no trackside laboratory is available. Sample B will be kept by the laboratory staff as a reserve sample, to be used for a second analysis if required. All samples are accompanied by a copy of the Fuel Sample Declaration form. Costs for the analyses of sample A and B are paid by FIM.
- 9) Sample C is handed over to the FIM, accompanied by a copy of the Fuel Sample Declaration form, for safeguarding in case of protests and/or a request for a counter-expertise by the FIM appointed laboratory. Costs for the analyses of sample C are paid by the team concerned.
- 10) As soon as possible after completing the testing, the Fuel Analyst/FIM appointed laboratory will report the results of the fuel sample analyses directly to the FIM appointed Official, with a copy to the rider, the relevant Commission Director and CTI Secretariat (via ctr@fim.ch and cti@fim.ch).
- 11) In the case of non-conformity of the fuel, the FIM appointed Official must notify the results to the FIM, the Race Direction (or the International Jury) and the rider/ team representative concerned. Failure of the sample to conform to the FIM fuel specifications results in the disqualification of the competitor. The result of the competitor's fuel sample analysis ("A" or "B" sample) more favourable to the competitor is taken into account.

- 12) Within 48 hours of the receipt of the notification of the results from the analysis of sample A and/or B, the team must notify the FIM and the FIM-appointed Official if a counter-expertise of sample C is requested.
- 13) The Race Direction (or the International Jury) takes a decision, immediately following the notification of the results of the final expertise. Any appeal against the decision of the Race Direction (or the International Jury) is heard by the FIM. Stewards appointed for the event at which the decision is taken. This takes place after the C sample has been analysed. For events without a Panel of Stewards, the appeal is lodged before the CDI.
- 14) **Fuel Sample Declaration Form**



FIM WORLD CHAMPIONSHIPS, CUPS AND PRIZE EVENTS Fuel Sample Declaration Form

Discipline	
Rider's name	
Rider's number	
Team	
Vehicle's make	

Fuel samples taken on date (dd/mm/yy)	
---------------------------------------	--

Fuel samples taken on:

MOTOCROSS	TRIAL	TRACK RACING	ENDURO/ISDE	RALLIES/BAJAS
<input type="checkbox"/> Practice	<input type="checkbox"/> Day 1	<input type="checkbox"/> Heat n°__	<input type="checkbox"/> Day 1	<input type="checkbox"/> Day 1
<input type="checkbox"/> Qualifying race	<input type="checkbox"/> Day 2		<input type="checkbox"/> Day 2	<input type="checkbox"/> Day 2
<input type="checkbox"/> Race 1			<input type="checkbox"/> Day n°__	<input type="checkbox"/> Day n°__
<input type="checkbox"/> Race 2				

	Container label n°	Container seal n°
Sample A		
Sample B		
Sample C		

The above listed details refer to fuel samples taken from the fuel tank of the motorcycle specified after the race whilst in the Check Area for a period of 30 minutes.

Sample "A" and "B" will go to the laboratory appointed by the FIM for analysis. Sample "C" will be safeguarded by the FIM in case a counter-expertise is required.

The serial numbers of the vial seals and labels have been verified and the accuracy of the listed information has been certified.

Team responsible's name	
Team responsible's signature	
FIM technical steward's name	
FIM technical steward's signature	
Date and time (dd/mm/yy, hh/mm)	

01.65 EQUIPMENT AND PROTECTIVE CLOTHING DURING PRACTICE AND RACE

The FIM cannot be held liable for any injuries that a rider or passenger may sustain from the use of a specific item of equipment or protective clothing.

65.01 Clothing and protectors

It is compulsory that riders/passengers wear either a suit or trousers and long-sleeve shirt.

It is recommended to use suit, trousers, long-sleeve shirts and undergarments made of textiles which are not fully constituted of nylon or spandex (e.g. Lycra, Elastan), in order to avoid degradation in case of abrasion (friction).

Moreover, it is recommended that riders/passengers wear back, chest, elbow and knee protectors, incorporated within the suit or worn separately. It is recommended that back and chest protectors comply with EN 1621-2 and prEN 1621-3, respectively.

Repaired overalls are acceptable provided that the repair guarantees protection to the same standard as the original garment. The Chief Technical Steward has the right to refuse any temporary repairs which are not deemed to provide the same protection as the original garment.

65.02 Footwear

Footwear, in a good condition, made of leather or other materials having equivalent properties, shall be worn **and have a minimum height of 30 cm.**

65.03 Gloves

Riders/passengers shall wear gloves made of leather or other materials having equivalent properties.

65.04 Eye protection

Riders/passengers shall wear goggles. The use of glasses, helmet visors and "tear offs" **or "roll offs"** is also permitted. The material used for glasses, goggles and visors must be made of shatter-proof material. Helmet visors must not be an integral part of the helmet.

Eye protectors which cause visual disturbance (e.g. scratched) must not be used.

01.67 WEARING OF HELMETS

- It is compulsory for all participants taking part in practice and races to wear a protective helmet. The helmet must be properly fastened, be of a good fit, and be in good condition. The helmet must have a chin strap type 'retention system'.
- **For all participants using a helmet with a protective or non-protective chin guard, the chin guard shall not block the rider's vision. Moreover, only chin guards designed by the manufacturer for the helmet in question may be used.**
- **Helmets constructed with an outer shell made of more than one piece are not permitted (e.g. they must not contain any seam).**
- **A retention system with a strap and the double D ring closing system is recommended.**
- All helmets must be marked with one of the official international standard marks mentioned in Art. 01.70. **Any FMN approval marks do not substitute the official international standard marks.**
- A helmet is made to provide protection. It is not a platform to attach foreign objects. Cameras or other accessories are NOT permitted and shall not be attached to the rider's helmet.

Failure to observe the above rules will entail exclusion.

01.69 HELMET OPERATIVE INSTRUCTIONS

69.01

Scrutineers, under the supervision of the Chief Technical Steward, may check prior to practice and the races that all helmets meet the technical requirements.

69.02

If a helmet does not meet the technical requirements **or** is found to be defective, the Technical Steward must remove all approval marks and retain the helmet until the end of the event. The rider must submit another helmet for approval by the Technical Steward. After an accident involving impact, the helmet must be presented to the Technical Steward for examination.

69.03

All helmets must be intact and no alteration must have been made to their construction.

69.04

The Chief Technical Steward/Technical Steward may ask a rider for the following checks before the rider is permitted to take part in practice of the race:

69.04.1 That the helmet fits well on the rider's head.

69.04.2 That it is not possible to slip the retention system over the chin, when fully fastened.



69.04.3 That it is not possible to pull the helmet over the rider's head by pulling it from the back of the helmet.

01.70 RECOGNISED INTERNATIONAL HELMET APPROVAL MARKS

Helmets must conform to one of the recognised international standards:

EUROPE	ECE 22-05
JAPAN	JIS T 8133:2007 (valid until 31.12.2019) JIS T 8133:2015
USA	SNELL M 2010 (valid until 31.12.2019) SNELL M 2015

Examples of labels are reported below (for Europe, the country numbers which have granted the approval are also indicated):

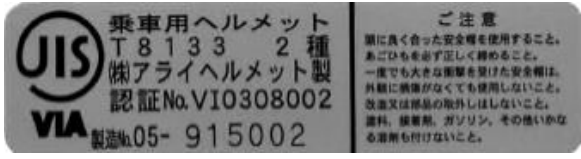
EUROPE	 <p>051406/J-1952 </p> <p>a = 8 mm min.</p> <p>3/ 1 for Germany, 2 for France, 3 for Italy, 4 for the Netherlands, 5 for Sweden, 6 for Belgium, 7 for Hungary, 8 for the Czech Republic, 9 for Spain, 10 for Yugoslavia, 11 for the United Kingdom, 12 for Austria, 13 for Luxembourg, 14 for Switzerland, 15 (vacant), 16 for Norway, 17 for Finland, 18 for Denmark, 19 for Romania, 20 for Poland, 21 for Portugal, 22 for the Russian Federation, 23 for Greece, 24 for Ireland, 25 for Croatia, 26 for Slovenia, 27 for Slovakia, 28 for Belarus, 29 for Estonia, 30 (vacant), 31 for Bosnia and Herzegovina, 32 for Latvia, 33 (vacant), 34 for Bulgaria, 35 (vacant), 36 for Lithuania, 37 for Turkey, 38 (vacant), 39 for Azerbaijan, 40 for The former Yugoslav Republic of Macedonia, 41 (vacant), 42 for the European Community (Approvals are granted by its Member States using their respective ECE symbol), 43 for Japan, 44 (vacant), 45 for Australia, 46 for Ukraine, 47 for South Africa and 48 for New Zealand. Subsequent numbers shall be assigned to other countries in the chronological order in which they ratify or accede to the Agreement Concerning the Adoption of Uniform Technical Prescriptions for Wheeled Vehicles, Equipment and Parts which can be Fitted and/or be Used on Wheeled Vehicles and the Conditions for Reciprocal Recognition of Approvals Granted on the Basis of these Prescriptions, and the numbers thus assigned shall be communicated by the Secretary-General of the United Nations to the Contracting Parties to the Agreement.</p>
JAPAN	 <p>乗車用ヘルメット T 8133 2種 樹アライヘルメット製 認証No.V10308002 製造社 05-915002</p> <p>ご注意 頭によく合った安全帽を使用すること。 あごひも必ず正しく締めること。 一度でも大きな衝撃を受けた安全帽は、 外観に損傷がなくても使用しないこと。 改造又は部品の変更はしないこと。 塗料、接着剤、ガソリン、その他いかなる 溶剤も付けないこと。</p>
USA	

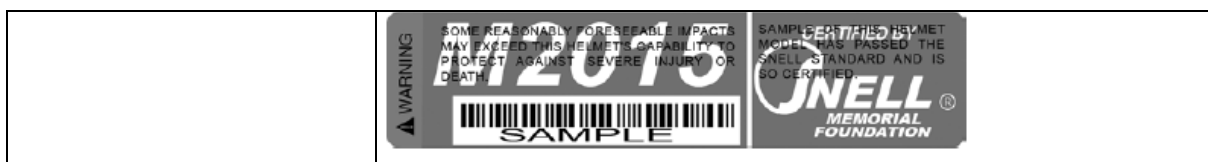

01.73 NATIONAL COLOURS FOR HELMETS

In competitions between national teams (e.g. FIM Trial of Nations), it is compulsory that the helmet's overall graphics represent the colours of the team's national flag or the colours as mentioned in the table below. The national flag can be replicated in stripes, bands or other patterns.

Andorra	FMA	White with vertical blue, yellow and red bands
Argentina	CAMOD	White with blue horizontal band
Australia	MA	Green and yellow sides, red, white & blue representation of the Australian flag across the top
Austria	OeAMTC	Bright red with a 60 mm wide black band and the label of the OeAMTC in a white field on the front side
Belgium	FMB	Yellow
Brazil	CBM	Yellow and green
Bulgaria	BMF	Green and red
Canada	CMA	White and 3 Red Maple leaves, one on front and one on each side
Chile	FMC	Red with blue band and yellow stars
China	CMSA	Red and yellow
Czech Republic	ACCR	Blue with red, white and blue border
Denmark	DMU	Red and white
Finland	SML	White with blue cross
France	FFM	Blue
Germany	DMSB	White with black border
Great Britain	ACU	Green
Greece	ELPA	White with blue border
Hungary	MAMS	Red and green
Ireland	MCUI	Green and orange
Italy	FMI	Red with one green and one white horizontal band
Japan	MFJ	White with red circle on top
Kenya	KMSF	Black, Red, Green, with white bands and the country name KENYA on both sides.
Luxembourg	MUL	Purple
Mexico	FMM	White with green and red border
Monaco	MCM	Blue and white
Netherlands	KNMV	Orange
New Zealand	MNZ	White with black kiwi on front
Norway	NMF	Red and blue
Peru	FPEM	Red with 75 mm wide white strips and blue and yellow chequered border

Poland	PZM	White with red band
Portugal	FNM	White
Rumania	FRM	Black with vertical blue, yellow and red bands with national emblem.
Russia	MFR	White with a red border and a vertical red band with star
San Marino	FSM	White with the San Marino National emblem
Slovakia	SMF	Blue, red and white
South Africa	MSA	Black, green, blue and red with yellow and white bands
Spain	RFME	Yellow and red
Sweden	SVEMO	Blue and yellow
Switzerland	FMS	Red with white cross
Uruguay	FUM	Light blue
USA	AMA	Blue with 2 white bands

In addition, the defending FIM Team World Champion is allowed to wear the rainbow colours on the helmet.

The rider's personal sponsors may be part of the overall graphics or displayed in a separate and dedicated area below the goggles strap (usually horizontal). The helmet model of each of the riders of a team may be different, but the graphics must have a similar visual appearance.

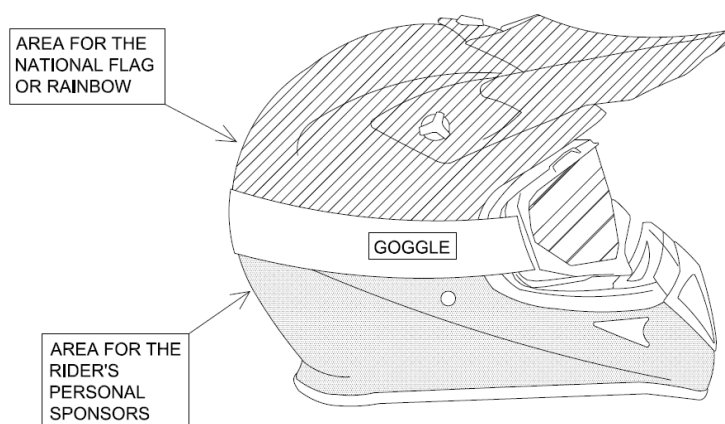

The overall graphics on the helmet must always be approved, in any case, by the FMN of the team.

Whenever a team is using a helmet and there is a case of *force majeure* (e.g. change of rider, broken helmet, etc.), the helmet in question can be replaced by any other helmet, provided that it complies with the FIM Technical Rules for the current year and has been presented to the Technical Stewards of the event.

01.75 BADGE OF THE FIM

Under certain circumstances the FIM may permit the use of the FIM badge on certain equipment in order to show that the latter conforms to the standards laid down by the

FIM. When this authorisation is granted and provided the equipment on which it appears is in good condition, the badge is then the guarantee of the conformity with the standard set by the FIM.

01.77 TECHNICAL VERIFICATIONS

77.01 Preparation

- Prior to the Technical Verifications, it should be decided who is doing what and note decisions. "Efficiency" must be the watchword. Always keep cheerful and remember the reasons for scrutineering: SAFETY AND FAIRNESS.
- Before the START of the competition, a closed and guarded area (closed parc/parc-fermé) shall be prepared.
- Inspection must take place under cover with a large enough area (min. surface 50 sq. metres).
- Inspection area must be supplied with the necessary equipment, including tables, chairs, electric light and power outlet.
- Weighing apparatus must be accurate, practical **and have a minimum resolution of 100g**. Certified master weights and their certificate must be available for verifying.
- The necessary tools are listed below:
 - ✓ Revolution meter
 - ✓ Sound meter, calibrator **and spare batteries**
 - ✓ Slide calliper (for verifying engine capacity, carburettor diameter, etc.)
 - ✓ Depth gauge
 - ✓ Steel measuring tape
 - ✓ Arrangement for measuring ground clearance **(for Sidecars)**
 - ✓ Seals
 - ✓ Weighing apparatus (to be provided by the **Promoter**) (and set of reference weights)
 - ✓ Tools for measuring the engine capacity
 - ✓ Lampoil tester for measuring the cylinder capacity **is recommended and when used, it indicates the cylinder capacity. When a more precise measurement is required, the Chief Technical Steward may ask to take the cylinder head off the cylinder.**
 - ✓ Colour for marking parts
 - ✓ Heat resistant **stickers** or paint for marking the silencer **(and cleaner)**
 - ✓ Magnet
 - ✓ Adequate fuel sample bottles
 - ✓ PC with CD Drive + **updated operating system**
 - ✓ Printer, etc. are recommended
 - ✓ Calculator

- The necessary documents are listed below:
 - ✓ Supplementary Regulations
 - ✓ FIM Technical Rules - current year
 - ✓ FIM Rules of the discipline concerned
 - ✓ FIM Sporting Code
 - ✓ Homologation papers (if applicable)
 - ✓ Writing material
 - ✓ Technical Verifications forms
- All necessary measures and administrative equipment should be in place at least 1/2 hour before the start of the Technical Verifications is due to open (time in Supplementary Regulations).

77.02 Verifications

- The Technical Verifications before the official practice should last at least 30 min, before the race last at least one hour, after the race last at least 30 min.
- The technical control must be carried out in conformity with the procedure and times fixed in the CTR Rules and the Supplementary Regulations of the event.
- The Sound control must be carried out first. The Sound level will be recorded in the Technical Verifications form. The exhaust silencer will be marked with paint.
- **An example of minimum verifications that shall be performed is given below:**

- | |
|--|
| <ol style="list-style-type: none"> 1. Sound test → sticker 2. Cut-off switch + self-closing throttle control 3. Make + model + fuel 4. Vehicle identification plate/chassis number → sticker 5. Registration plate 6. Weight + ballast 7. Fuel tank → sticker 8. Guard for the countershaft sprocket and rear sprocket 9. Handlebar protection 10. Front/rear disc brake protection 11. Helmet + national colours → sticker |
|--|

- An overall inspection of the motorcycle must be carried out in conformity with the FIM rules. Accepted motorcycles will be marked with paint or a sticker.
- The Technical Verifications will only be carried out when the Technical Verifications form of the motorcycle has been presented by the **rider or his/her mechanic**.

77.03 FMNR Chief Technical Steward and technical stewards

- The Chief Technical Steward must be in attendance at an event one hour before the Technical Verifications are due to begin. He must inform the Clerk of the Course/FIM Race Director and CTI Delegate, if present, of his arrival.
- The Chief Technical Steward must ensure that all technical stewards appointed for the event carry out their duties in a proper manner. The Chief Technical Steward shall appoint the technical stewards to individual posts for the race, practices and final control.
- Scrutineers can have different tasks, but the team of scrutineers must have a minimum of three persons. At least one person must be a holder of an FIM SENIOR Technical Stewards Licence.
A minimum number of scrutineers is required according to the following:
 - Checking of documentation: one
 - Sound test, silencer marking: two
 - Machine weight: one
 - Machine inspection, helmet and clothing: two
- **The Sound Control Officer (SCO) must be holder of an FIM Technical Stewards' license. The Sound Control Officer (SCO) must be holder of a valid FIM Technical Steward's license, come with good knowledge and experience of the sound control and application of the test method.**
- The Chief Technical Steward must inform the Clerk of the Course/FIM Race Director of the results of the Technical Verifications. The Chief Technical Steward will then draw up a list of accepted machines and submit this list to the Clerk of the Course/FIM Race Director.
- The Chief Technical Steward has the right to look/ inspect any part of the motorcycle at any time of the event.
- All technical stewards shall be well informed and shall make sure their FMN has supplied them with all technical "updates" that may have been issued subsequent to the printing of the Technical Rules books.

77.04 FIM Permanent Technical Delegate

- **The FIM Permanent Technical Delegate must report any concern or deficiency related to the Technical Verifications to the Clerk of the Course/FIM Race Director and present proposals to resolve such concerns.**

77.05 Rider and/or mechanic

- **The rider and/or the mechanic must attend at least once the Technical Verifications with the (rider's) machine within the time limits stated in the Supplementary Regulations.**

- The maximum number of persons present at the technical verification will be the rider **and/or** the mechanic, plus one other person. In addition, for Team events, the Team Manager may also be present.
- A rider remains at all times responsible that his/her machine and his/her personal protective gear are in conformity with the FIM Technical Rules for Trial motorcycles.
- **The rider and/or the mechanic** must present a clean motorcycle in conformity to the FIM rules and a duly filled in and confirmed Technical Verifications form.
- **A rider and/or the mechanic** must present one (1) motorcycle for the Individual Trial World Championship and up to two (2) motorcycles for the Indoor Trial World Championship.
- **The rider and/or the mechanic** must present the rider's protective wear (equipment), e.g. helmet and bib with prescribed starting number.
- **Any rider and/or the mechanic** failing to report as required by the provisions below may be excluded from the meeting.
- **The Clerk of the Course/FIM Race Director may prohibit any person who does not comply with the rules, or any rider who could be a danger to other participants or to spectators, from taking part in the competitions.**

01.78 DANGEROUS MACHINES

If, during practice or the race, a Technical Steward finds that a machine is defective and might constitute a danger to other riders, he must immediately notify the Clerk of the Course/FIM Race Director or his deputy. It is their duty to exclude such a machine either from the practice or from the race itself.

01.79 SOUND LEVEL CONTROL

NOTES:

- **EPVs (Group J) are exempted from sound level control.**
- **For the first World Championship event, all competitors' machines will be checked for sound level. After the first event, the machine of a 'wild card-' or 'one event' rider, will be checked for the sound level, as well as any other rider's machine on a random basis.**
- **Excessively loud machines must always be checked, regardless of the participants' status.**

In order to pursue the measures taken to reduce the sound level in favour of environment and in the framework of the 'RIDE QUIET' campaign, a new method for measuring the sound level called "2 metre max" is applied as from 2013 in all 'all-terrain' disciplines.

The technical specifications and the resources to apply such a method, for the use of the technical stewards and officials, are outlined in the present Article.

The "2 metre max" method shows a very good correlation between the sound power level (L_{WA}) issued by motorcycles in full acceleration, and the maximum sound pressure levels measured at proximity of the same motorcycles, with engines at idle and quickly taken to their maximum rotational speeds.

The "2 metre max" method will consist in quantifying not only the sound level produced by the silencer of the exhaust, but the maximum global sound level achieved by the motorcycle when the engine rpm's are raised to the maximum engine speed, limited by a natural regulation (for 2 strokes) or rev limiters (for 4 strokes).

Only the sound levels measured with the "2 meter max" method will be considered by the technical stewards and by the Race Direction/Jury of the event to decide whether the motorcycle is in conformity with the maximum sound levels authorised.

79.01 Preparation of the sound meter

For all FIM Championship and Prize events, a sound meter Class 1 (type 1) is required to measure the sound levels. For all other Championships, a sound meter of Class 1 or 2 (type 1 or 2) is required.

Sound level measuring equipment must also include:

- a compatible calibrator, which must be used immediately before testing begins and always just prior to a re-test if a disciplinary sanction may be imposed;
- a tachometer.

Two sets of equipment must be available in case of failure of tachometer, sound level meter or calibrator during technical control.

The sound meter shall be prepared by applying the following procedure:

- Activate the 'A' weighing
- FAST time weighting must be activated
- Select range High 80~130 dB
- Calibrate the sound meter at 93.5 dB or 113.5 dB to take into account the incidence of the wind foam ball
- Position the wind foam ball on the microphone
- Activate the function MAX MIN – set on MAX

79.02 Set up of the sound meter and the motorcycle

The sound levels will be measured with the microphone fixed on a tripod at a height of 1.35 m above the ground, in horizontal (levelled) position. It is helpful to have the microphone equipped with an extension cable to the sound meter.

For the place and position of the motorcycle, ensure that there are no solid obstacles within 10 m around the microphone.

Depending on the vehicle, the sound meter will be positioned

- for Solo motorcycles (except for Snowmobiles): at an angle of 45° from the longitudinal axis of the vehicle, on the exhaust side, at a distance of 2 m behind the vehicle (measured from the point where the centre of rear tyre touches the ground).
- for Solo motorcycles with 2 exhaust outputs: at an angle of 45° from the longitudinal axis of the vehicle, on the side of the air intake, at a distance of 2 m behind the vehicle (measured from the point where the centre of rear tyre touches the ground). Note: if a central positioned air intake is used, both sides will be tested.
- for Snowmobiles: at an angle of 90° from the longitudinal axis of the vehicle, on the side of the silencer, at a distance of 2 m next to the vehicle (measured from the silencer exit). Note: the use of only one silencer is allowed for Snowmobiles.
- for Sidecars: at an angle of 45° from the longitudinal axis of the vehicle, on the sidecar side, at a distance of 2 m behind the vehicle (measured from the point where the side tyre touches the ground).
- for Quads: at an angle of 45° from the median longitudinal axis of the vehicle, at a distance of 2 m behind the vehicle (measured from the point where the line drawn perpendicular to the rear axle touches the ground).
- for Quads with the exhaust moved out of the median axis: at an angle of 45° from the exhaust axis, on the offset side, at a distance of 2 m behind the vehicle (measured from the point where the line drawn perpendicular to the rear axle touches the ground).

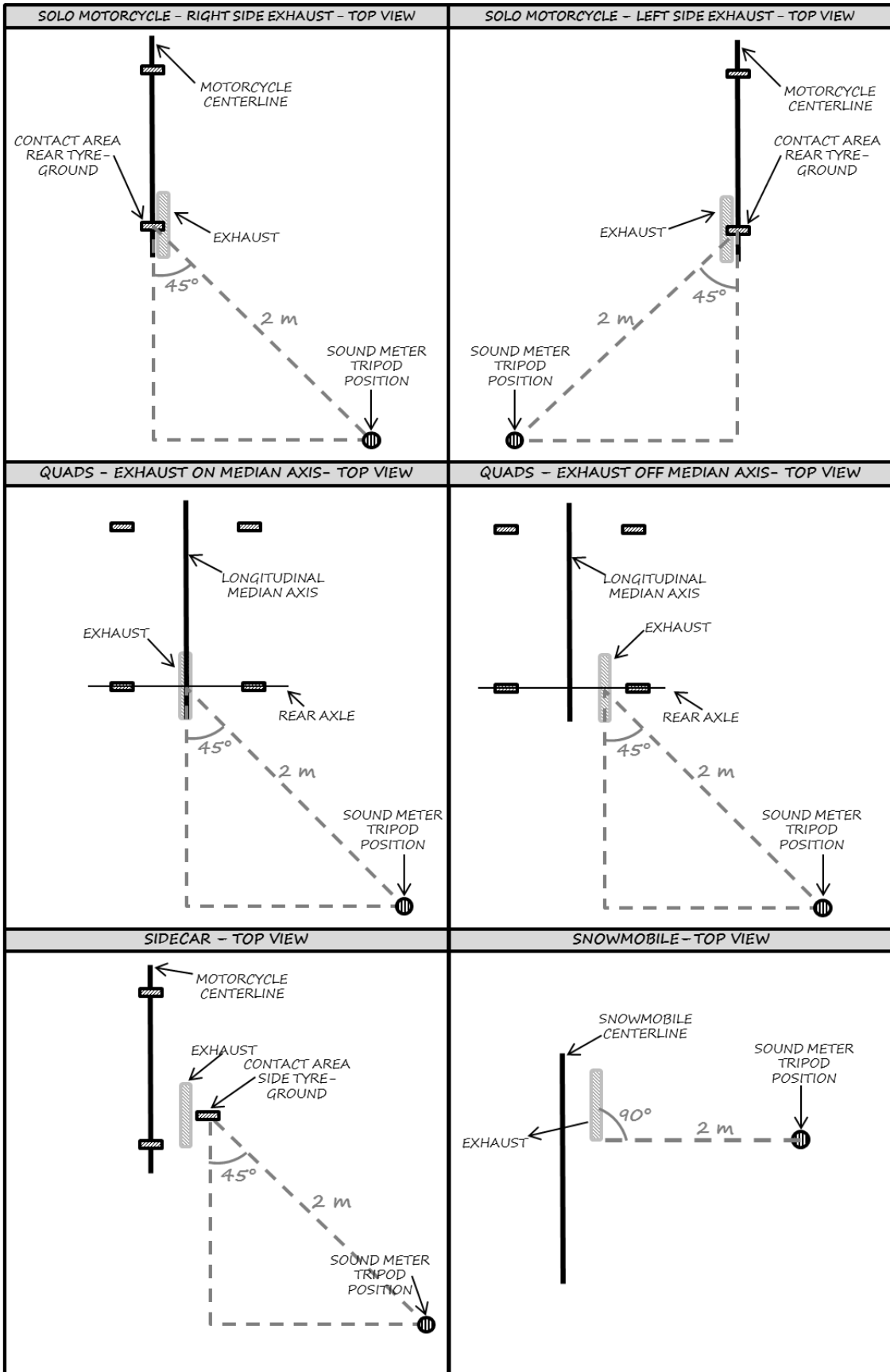

The sound level for engines with more than one cylinder will be measured on each exhaust end.

Silencers fitted with adapters aiming to reduce the sound level shall be permanently fitted.

To make repetitive measurements, all motorcycles can be positioned into a small frame fixed on the ground, making sure to respect the 45° requirements. **A squared frame helps the positioning of the motorcycle.**

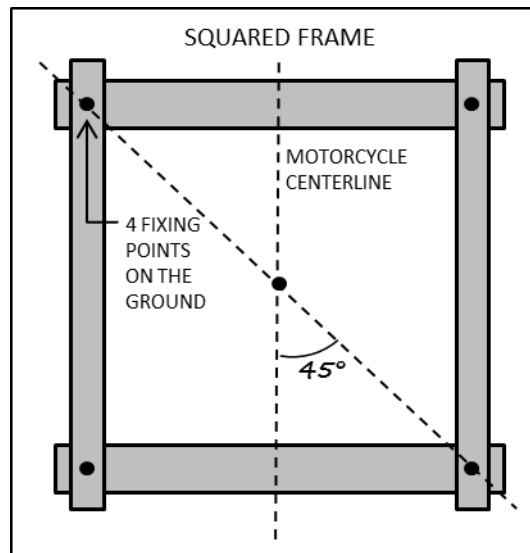

Vehicles which are not equipped with a gear box neutral must be placed on a stand.

It is preferred to make the tests on soft ground, not reverberating, i.e. grass or fine gravel.

In other than moderate wind, machines should face forward against the wind direction.

The ambient sound should not exceed 90 dB/A within a 5 m radius from the power source during tests.

79.03 The test procedure

A technical steward (nominated as Sound Control Officer, "SCO") takes place next to the vehicle, opposite to the sound meter/microphone, in order not to screen or stand between the bike and the microphone.

The Sound Control Officer (SCO) must have arrived in sufficient time for discussions with the Clerk of the Course/FIM Race Director and other Technical Officials in order that a suitable test site and testing procedure can be agreed.

A second technical steward can be present to help. The rider can also be present.

It is strongly advised that the technical steward(s) use earplugs, a headset or ear protectors.

The measurement is made with motorcycle on its wheels, with a hot engine. During the sound test, only the rider may sit on the vehicle in the normal riding position.

A mechanic, placed on the left side of the motorcycle, shall disengage the clutch.

The SCO (and not others) shall open the throttle as fast as possible (instantly, within 0.3 s) until "full open throttle", in order to reach the maximum rpm value ("max. rpm").

When in doubt, it can be verified that such "max. rpm" value is higher than the rpm value at which the vehicle supplies its maximum power (kW) ("max. power rpm").

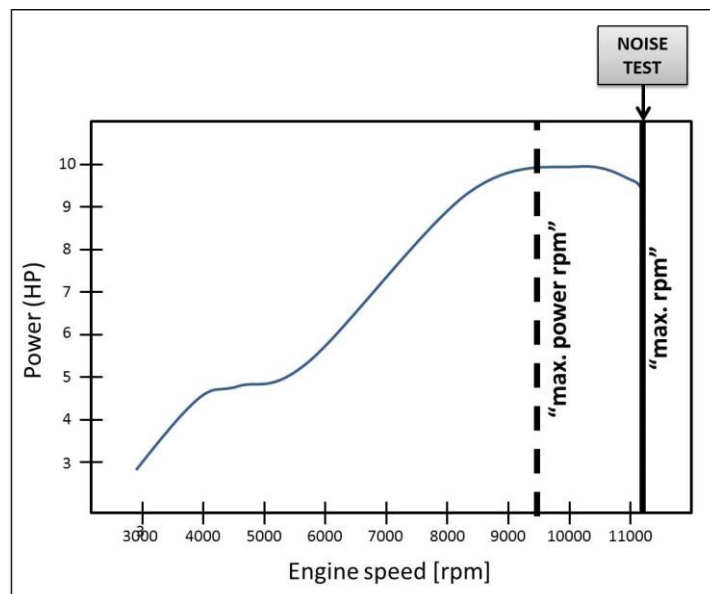

The SCO then keeps the engine at the "max. rpm" value for at least 1 s (or until there is an audible sign of over-revving the engine), during which the measurement is taken.

To conclude the test, the SCO releases the throttle quickly.

The maximum noise value (dB/A) registered during the measurement interval is then read on the sound meter and recorded. This noise value shall not be rounded down to the nearest whole number.

The noise value is then compared with the sound limits (see Art. 79.08).

The noise test can be "PASSED" or "NOT PASSED":

- "PASSED": The sound test is considered "passed" if the recorded noise value is below or equal to the sound limits of Art. 79.04. The silencer can then be marked by the SCO at the end of the test.

The silencer shall not be changed after verification, except for the spare silencer (see Art. 79.05) that has also been checked and marked.

The end opening of the silencer shall remain unmodified once it has been checked and marked.

- "NOT PASSED": The sound test is considered "not passed" if the recorded noise value is above the sound limits of Art. 79.08.
In this case, the vehicle (with the same silencer) can be presented again, but for two more tests maximum.
If the third test result is negative, the rider
 - can present a different silencer (in case the sound test was done before the race)
 - will receive a penalty (in case the sound test was done after the race).

For vehicles that have passed the sound test, the silencer is marked by the SCO at the end of the test.

The silencer shall not be changed after verification, except for the spare silencer (see Art. 79.05) that has also been checked and marked.

The end opening of the silencer shall remain unmodified once it has been checked and marked.

The sound meter is then reset by pushing on the side-line and armed by pushing on the side-line again.

Notes:

- If the engine starts to misfire, close the throttle slightly and re-open the throttle.
- If detonations appear, the measurement must be started again.
- For vehicles without an engine rev. limiter, the throttle will have to be opened not more than 2 s or until there is an audible sign of over-revving the engine.
- Even in case a vehicle has not exceeded the respective sound limit, if there is any doubt, the vehicle may be checked again.
- If the vehicle is unable to reach the "max. power rpm" value, the vehicle shall be refused. Any attempt by a participant to prevent his/her engine from reaching the "max. power rpm" will be considered a breach of the rules.
- In case the SCO doubts that the "max. power rpm" value (as declared by the manufacturers or previously obtained with the dyno test), he/she shall measure the engine speed with a tachometer connected to the spark.

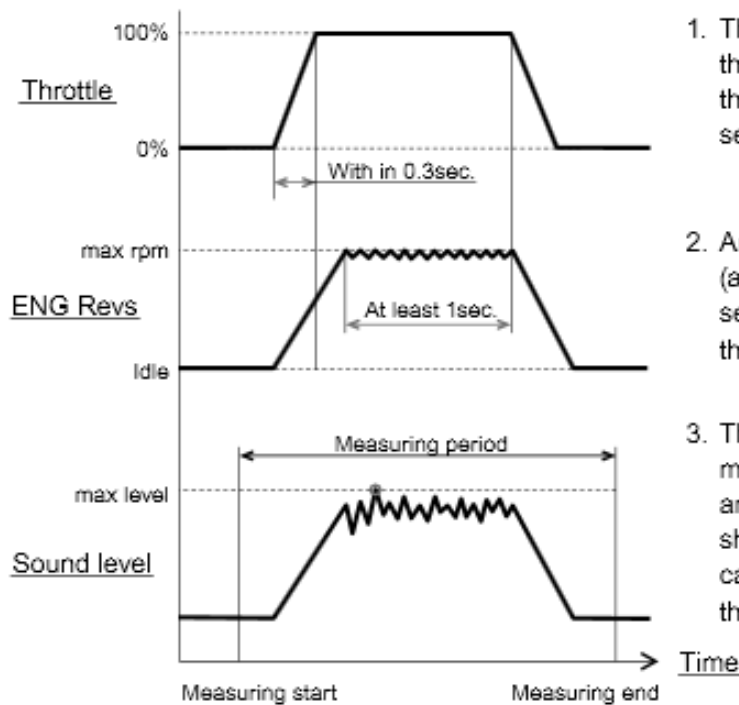

1. The Inspector shall open the throttle until full open throttle within 0.3 seconds.
2. And keep at the max rpm (at rpm limiter) at least 1 second. Then, release the throttle quickly.
3. The sound level is measured in the all period and the maximum level shall be recorded in any case. (automatically by the sound meter).

79.04 Sound limits

TRIAL World Championships, Cups and Prizes		
Type of engine	Sound limit	
	Before or during race	After race
2-stroke	103 dB/A	104 dB/A
4-stroke	105 dB/A	106 dB/A

NOTES:

- The values that have to be respected after the race take into account the degradation of the silencer (i.e. the limit is raised of 1 dB/A).
- **The values already take into account the accuracy of the method, which is estimated to be of 2 dB/A by using the current sound test equipment.**
- No deductions for ambient temperature, **pressure or altitude** are allowed.

79.05 Spare silencers

The rider or the mechanic can present at the sound control, together with the vehicle, one (1) spare silencer to be checked.

Other spare silencers may be presented after all participants have presented their vehicles, or on the following days of the event.

79.06

Action and decisions will depend on the Sporting Discipline concerned, and decisions taken during prior discussions with the FIM Technical Director and/or the Chief Technical Steward.

79.07

In a competition which requires a final examination of machines before the results are announced, this examination must include a sound control measurement of at least three machines chosen at the discretion of the Clerk of the Course/FIM Race Director in co-operation with the Chief Technical Steward. Refer to each discipline for more info.

Diagrams

Rule changes as of 01.01.2018

63.01.2 Unleaded petrol (incl. E10) will comply with the FIM specification if:

It has the following characteristics:

Property	Units	Min.	Max.	Test Method
RON		95.0	102.0	EN ISO 5164 or ASTM D2699
MON		85.0	90.0	EN ISO 5163 or ASTM D2700
Oxygen (includes 10% ethanol allowance)	% (m/m)		3.7	ISO 22854 or EN 13132 or elemental analysis
Nitrogen	% (m/m)		0.2	ASTM D 4629 or ASTM 5762
Benzene	% (V/V)		1.0	ISO 22854 or ASTM D6839 or ASTM D5580
Vapour pressure (DVPE) (for winter events)	kPa		95.0 (100.0)	EN 13016-1 (ASTM D5191)
Lead	mg/L		5.0	ICP-OES or AAS
Manganese	mg/L		2.0	ICP-OES or AAS
Density at 15°C	kg/m ³	720.0	785.0	EN ISO 12185 or ASTM D4052
Oxidation stability	minutes	360		EN ISO 7536 or ASTM D525
Sulphur	mg/kg		10.0	EN ISO 20846 or ASTM D5453
<u>Distillation:</u>				EN ISO 3405 or ASTM D86
E at 70°C	% (V/V)	20.0	50.0	
E at 100°C	% (V/V)	46.0	72.0	
E at 150°C	% (V/V)	75.0		
Final Boiling Point	°C		210	
Residue	% (V/V)		2.0	
Appearance	Clear and bright			Visual inspection
Olefins	% (V/V)		18.0	EN ISO 22854 or ASTM D6839
Aromatics	% (V/V)		35.0	EN ISO 22854 or ASTM D6839
Total diolefins	% (m/m)		1.0	GC-MS or HPLC
<u>Oxygenates:</u>				EN ISO 22854 or EN 13132
Methanol	% (V/V)		3.0	The only oxygenates permitted are paraffinic mono-
Ethanol (1)	% (V/V)		5.0	
Ethanol (E10) (1)	% (V/V)	5.0	10.0	

Isopropanol	% (V/V)		12.0	alcohols and paraffinic monoethers (of 5 or more carbon atoms per molecule) with a final boiling point below 210°C.
Isobutanol	% (V/V)		15.0	
<i>tert</i> -Butanol	% (V/V)		15.0	
Ethers (C5 or higher)	% (V/V)		22.0	
Others (2)	% (V/V)		15.0	

- a) The total of individual hydrocarbon components present at concentrations of less than 5% (m/m) must constitute at least 30% (m/m) of the fuel. The test method will be gas chromatography and/or GC/MS.
- b) The total concentration of naphthenes, olefins and aromatics classified by carbon number must not exceed the values given in the following table:

% (m/m)	C4	C5	C6	C7	C8	C9+
Naphthenes	0	5	10	10	10	10
Olefins	5	20	20	15	-	-
Aromatics	-	-	1.2	35	-	-

The total concentration of bicyclic naphthenes and bicyclic olefins may not be higher than 1% (m/m). The test method used will be gas chromatography.

- c) Lead replacement petrols, although basically free of lead, are not an alternative to the use of unleaded petrol. Such petrols may contain unacceptable additives not consistent with the FIM Fuel Regulations.

CHECKLIST

1. Sound test (if applicable)
2. Cut-off switch + self-closing throttle control
3. Make + model + fuel
4. Vehicle identification plate and chassis number
5. Registration plate (if applicable)
6. Weight + ballast
7. Fuel tank (if applicable)
8. Guard for the countershaft sprocket and rear sprocket
9. Handlebar protection
10. Front/rear disc brake protection (if applicable)
11. Helmet + national colours (if applicable)

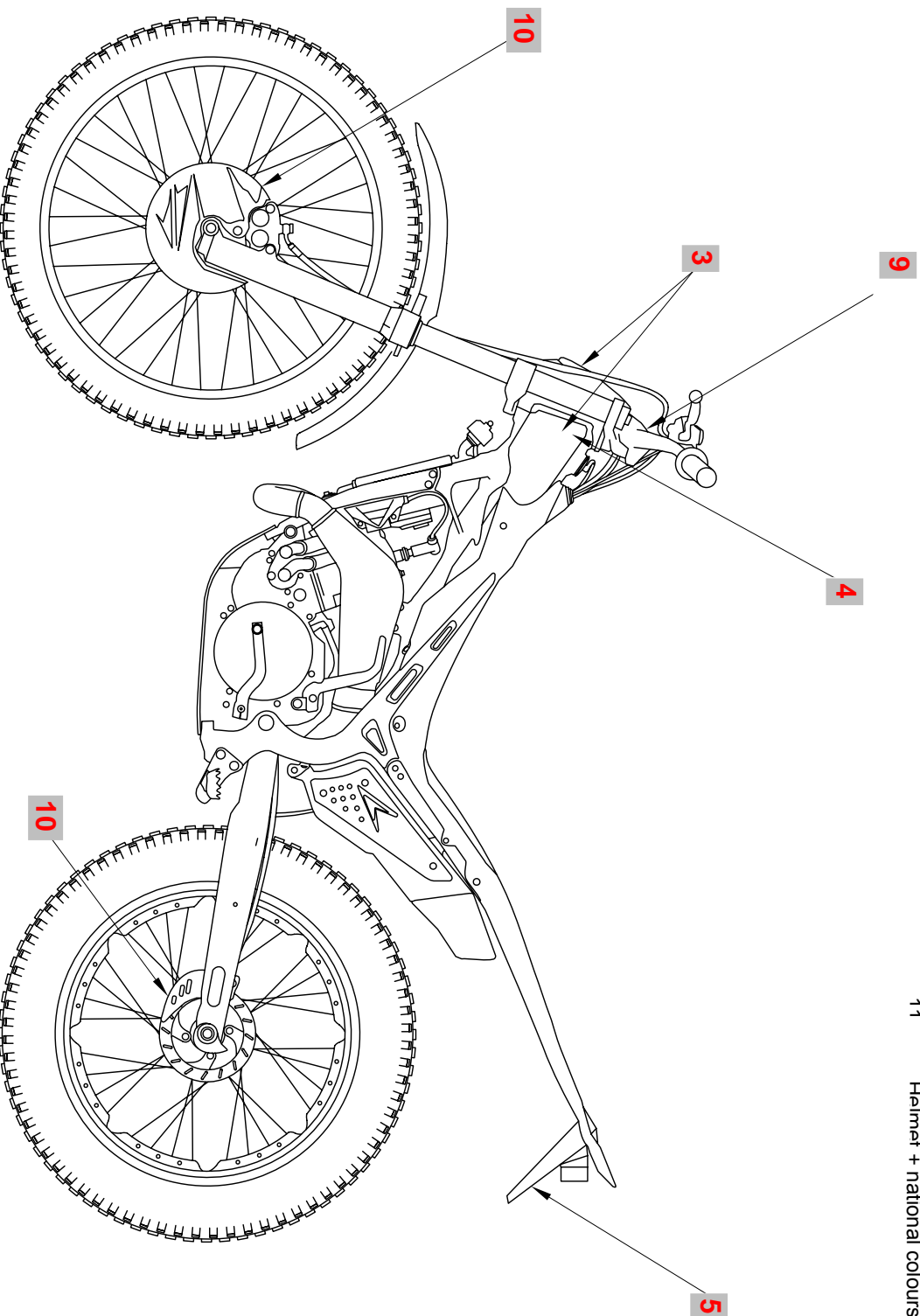

CHECKLIST

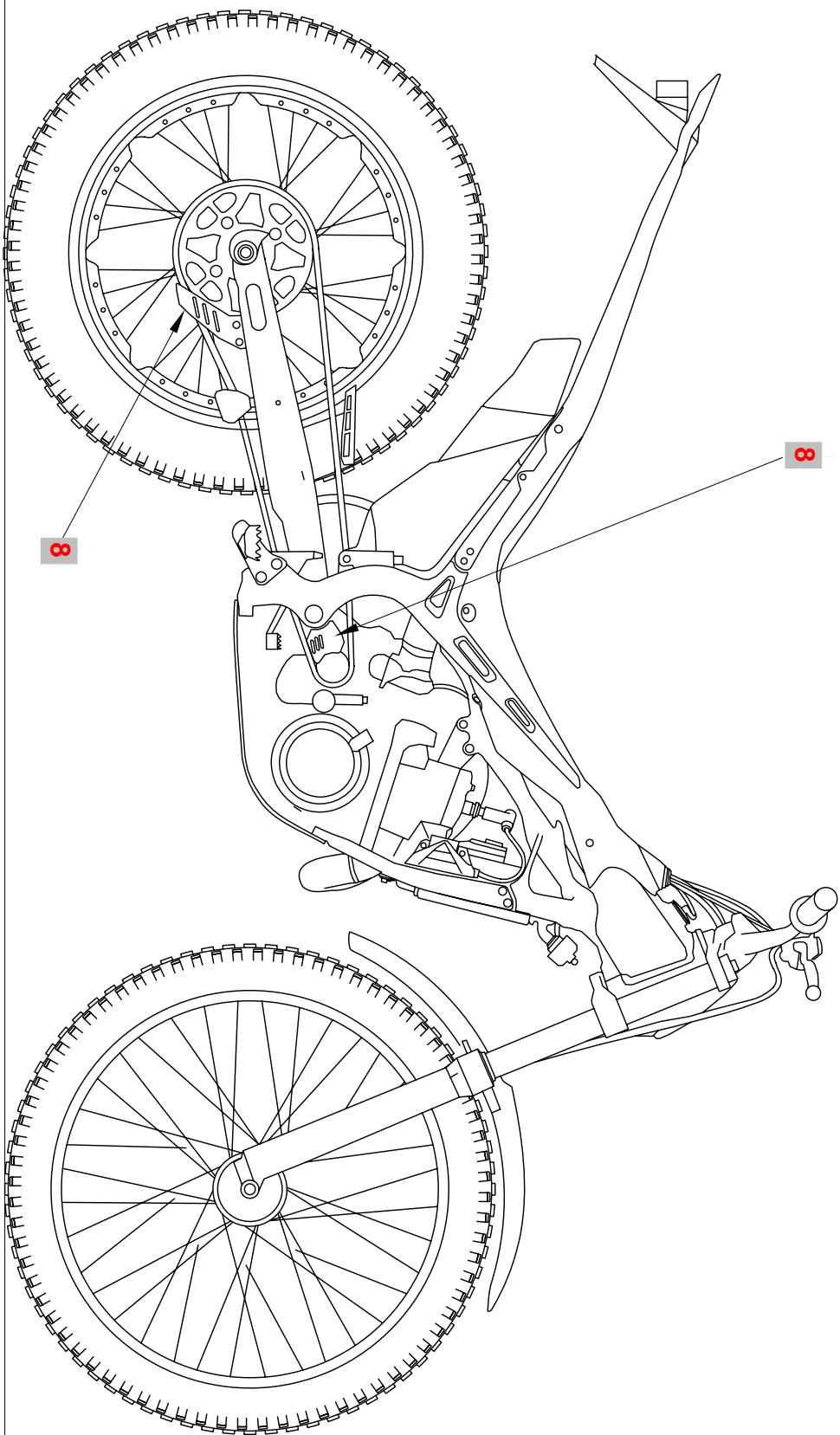

D

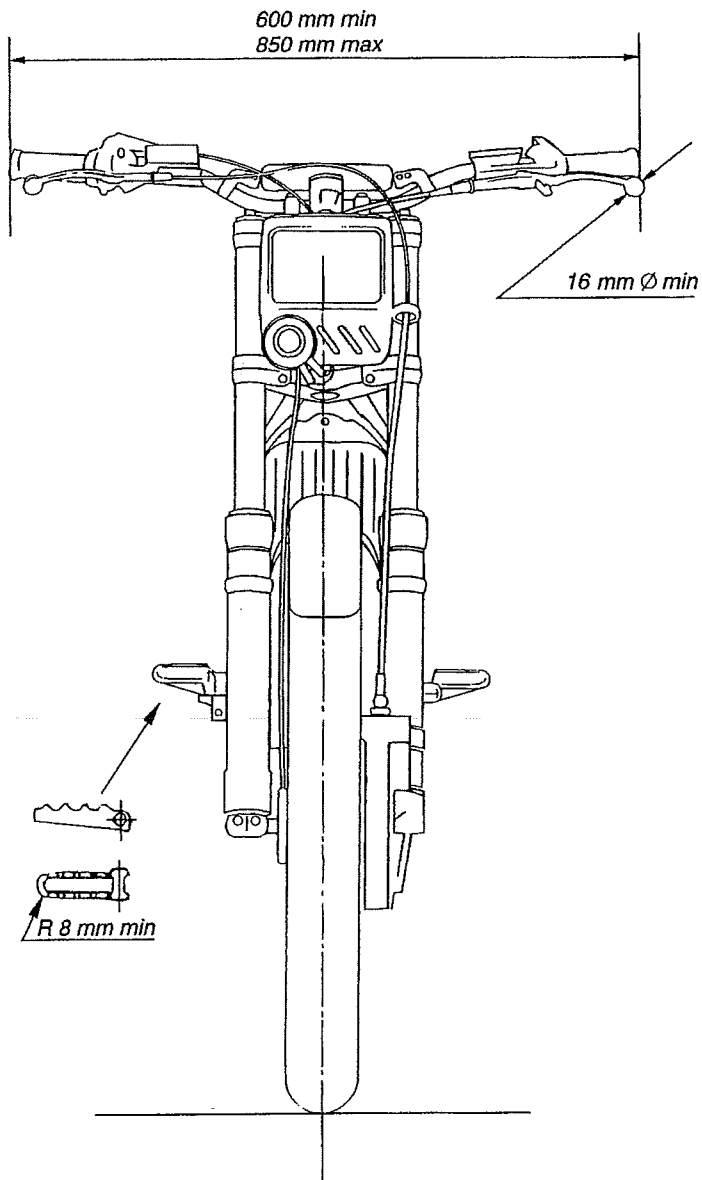

D bis

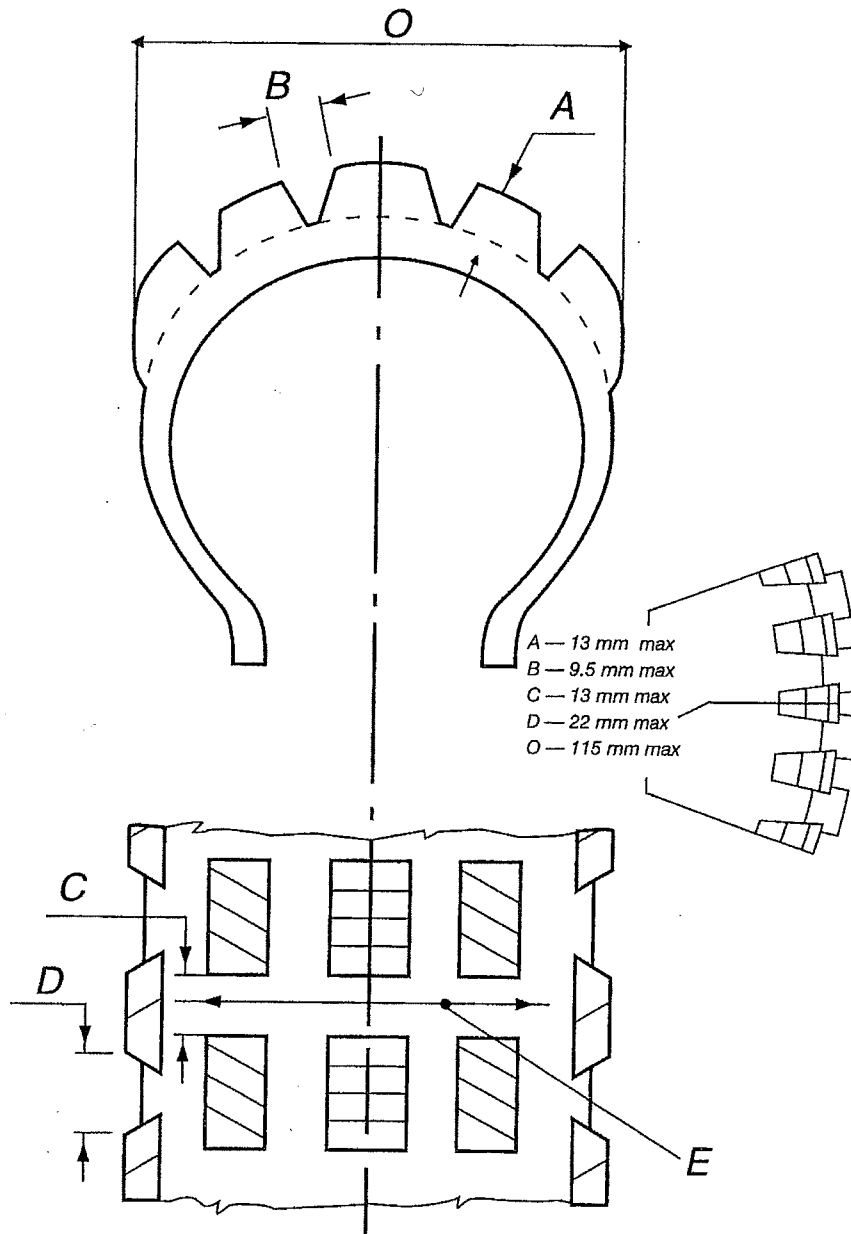

TRIAL / SIDECAR

N

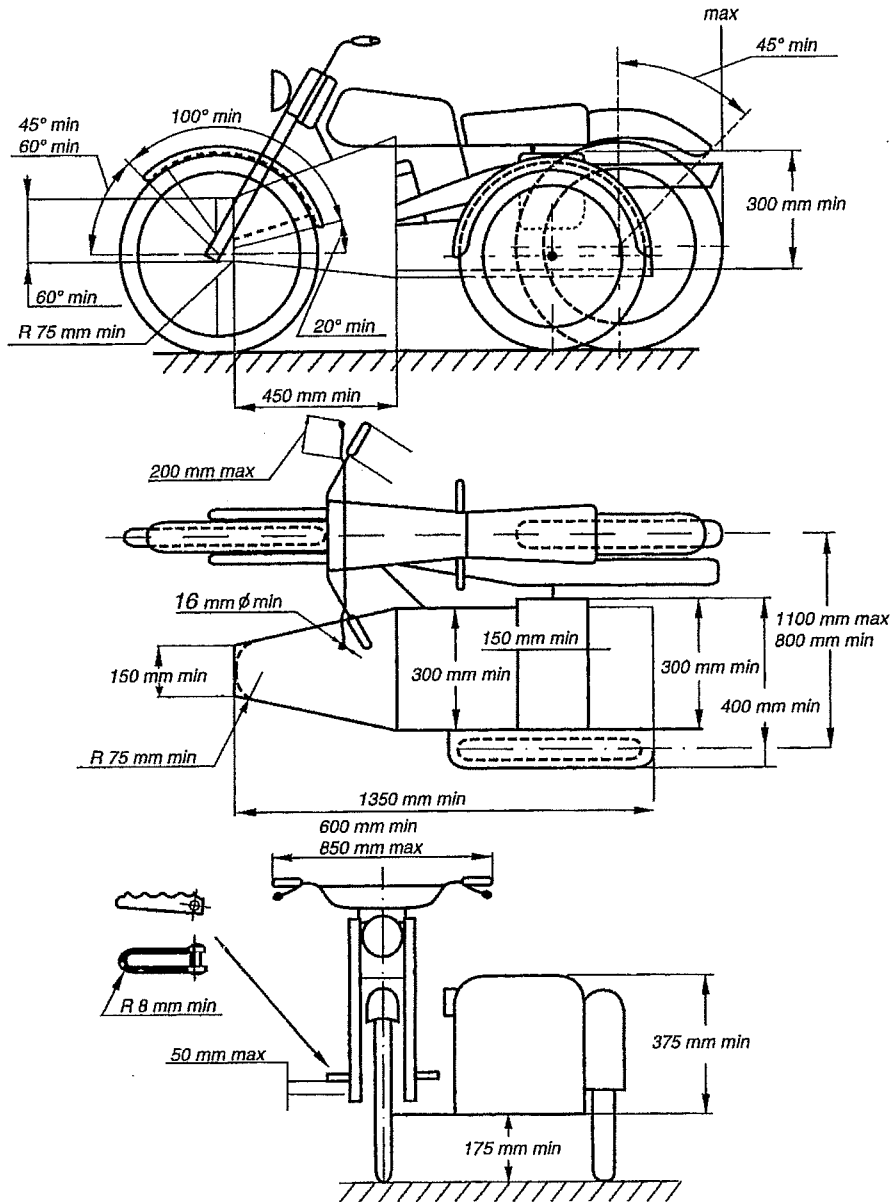

REAR BRAKE DISC

SOLID
OR
COVERED

SLOTS

Max 6mm

HOLES

Max \varnothing 6mm

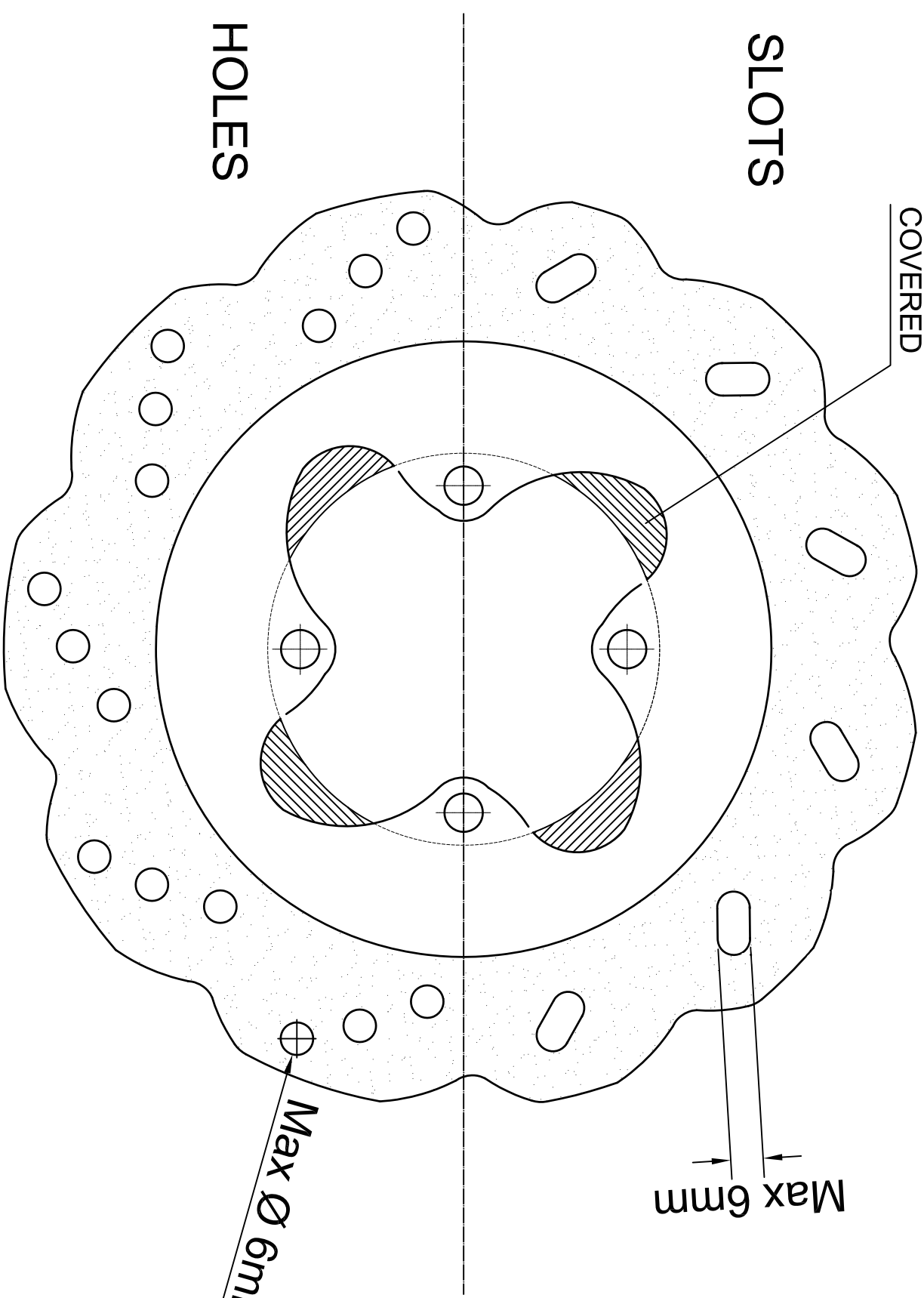

TEN FITTING TESTS FOR HELMETS **DIX TESTS D'ADAPTATION POUR LES CASQUES**

1. *Obtain correct size by measuring the crown of the head*
Avoir la bonne grandeur en mesurant le sommet de la tête
2. *Check there is no side to side movement*
Vérifier qu'il n'y ait pas de déplacement d'un côté à l'autre
3. *Tighten strap securely*
Serrer solidement la jugulaire
4. *With head forward, attempt to pull up back of helmet to ensure helmet cannot be removed this way*
Tête en avant, essayer de soulever le casque pour s'assurer qu'il ne peut pas être enlevé de cette façon



5. *Check ability to see clearly over shoulder*
Vérifier si vous pouvez voir clairement par-dessus l'épaule
6. *Make sure nothing impedes your breathing in the helmet and never cover your nose or mouth*
S'assurer que rien ne gêne votre respiration dans le casque et ne jamais couvrir le nez ou la bouche
7. *Never wind scarf around neck so that air is stopped from entering the helmet. Never wear scarf under the retention strap*
Ne jamais enrouler une écharpe autour du cou, car cela empêche l'air d'entrer dans le casque. Ne jamais porter d'écharpe sous la jugulaire
8. *Ensure that visor can be opened with one gloved hand*
S'assurer que la visière peut être ouverte avec une main gantée
9. *Satisfy yourself that the back of your helmet is designed to protect your neck*
S'assurer que l'arrière de votre casque a une forme telle qu'il vous protège la nuque
10. *Always buy the best you can afford*
Toujours acheter le meilleur que vous pouvez vous offrir



FÉDÉRATION INTERNATIONALE
DE MOTOCYCLISME

FIM-LIVE.COM

11, ROUTE DE SUISSE | CH - 1295 MIES

cti@fim.ch

6579003